

<b>I.E.S. ETI</b>		<b>HOJA DE PROCESO</b>		Nombre: Curso:	Máquina <b>Torno</b>
-------------------	--	------------------------	--	-------------------	-------------------------

Escala 1/1	Material F- 1120	Dimensiones en bruto	Denominación <b>Punta cónica</b>	Nº de pieza
---------------	---------------------	----------------------	-------------------------------------	-------------

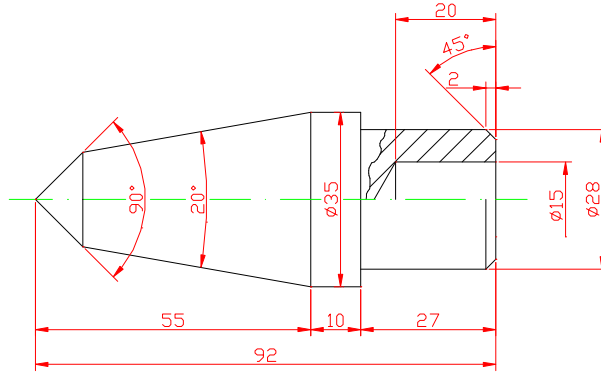

SF	OP	Designación	Croquis	Herramientas		NO pasadas	V mm/m	n r.p.m.	a mm/r	T
				Trabajo	Control					

Observaciones:	Tiempo total
----------------	--------------

Comenzado _____	Día			Nota	Final
Terminado _____	Nº horas			Acabado ____	Tiempo ____
Tiempo invertido ____	Tiempo estimado 6 horas			Medidas ____	Proceso ____