

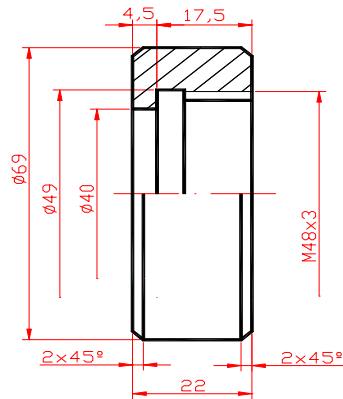



<b>I.E.S. ETI</b>		<b>HOJA DE PROCESO</b>		Curso:	Torno
Escala 1/1	Material F- 1120	Dimensiones en bruto	Denominación		Nº de pieza



SF	OP	Designación	Croquis	Herramientas		NO pasadas	V mm/m	n r.p.m.	a mm/r	T
				Trabajo	Control					

Observaciones:						Tiempo total		
Comenzado _____	Día					Nota		Final
Terminado _____	Nº horas				Acabado ____	Tiempo ____		
Tiempo invertido ____	Tiempo estimado horas				Medidas ____	Proceso ____		

